

REV.	DESCRIPTION	DATE	BY

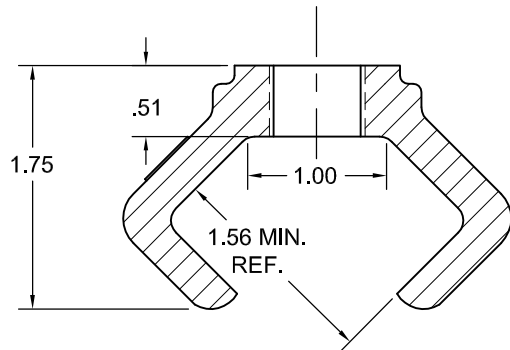
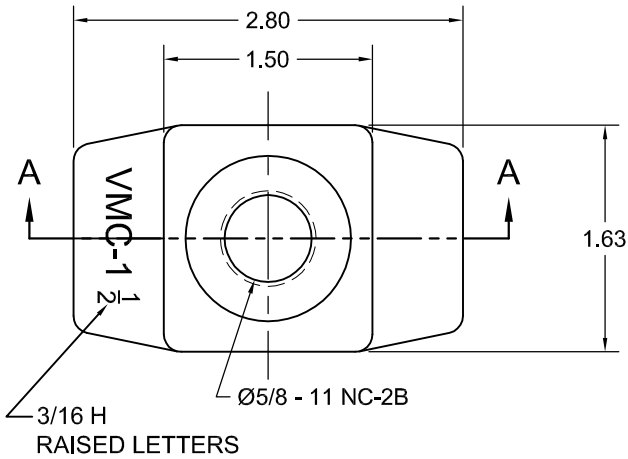

SECTION A-A

NOTES:

1. MATERIAL : GRAY CAST IRON
2. ALL RADII TO BE 1/8"R U.O.N.
3. TOLERANCES TO BE ±.030 U.O.N.
4. EST. PIECE WT: .56 LB.

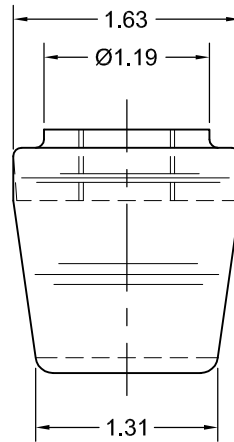
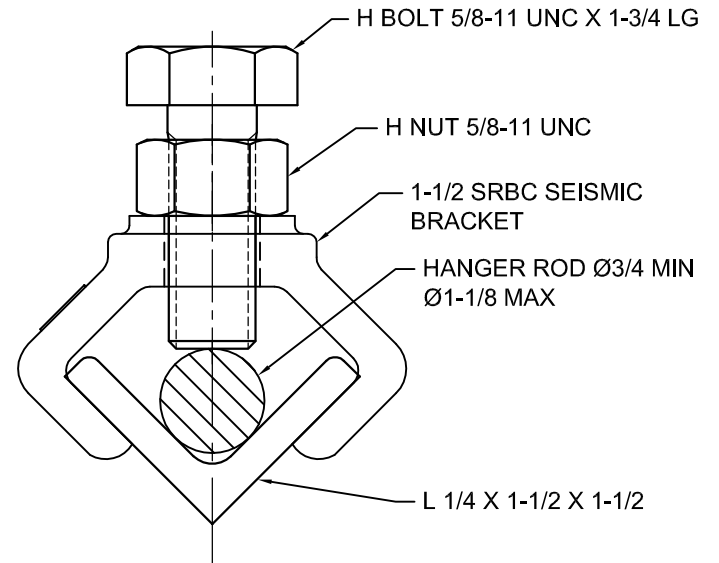

OTHER MATERIALS, COMPOUNDS, OR FINISHES WITH EQUAL OR SUPERIOR PROPERTIES MAY BE SUBSTITUTED AS THEY BECOME AVAILABLE.

CERTIFIED FOR:

JOB NAME: _____
 CUSTOMER : _____
 CUSTOMER P.O.: _____
 SALES ORDER: _____

MODEL SRBC 1.5 SEISMIC RESTRAINT
 ROD STIFFENER BRACKET



THE VMC GROUP
The Power of Together
 Bloomingdale, NJ 07403
 Houston, TX 77041

SCALE :

NONE

SHEET:



DRAWING NO.:

REVISION